

# SAWS Production Facility Fence Replacement Project

**Carl Daylong**

Foreman – Facility Maintenance

**Gina Cappa**

Contract Administration Specialist – Contracting

August 20, 2015

SAWS Production Facility Fence Replacement Project



# Mandatory Pre-Bid Objectives

- During this meeting the following will be discussed:
  - Project Overview
  - Solicitation Overview

# Contract Background

**Project Objective:** Select a firm to remove and replace :

- Approximately 2,700 linear feet of chain link fence and gates
- Except as indicated at Judson site this is a replace in place project
- Review contract and scope of work for project
- Submit questions in writing

# Judson- 5330 Stahl Rd





# Judson- 5330 Stahl Rd



# 2727 Foster Road

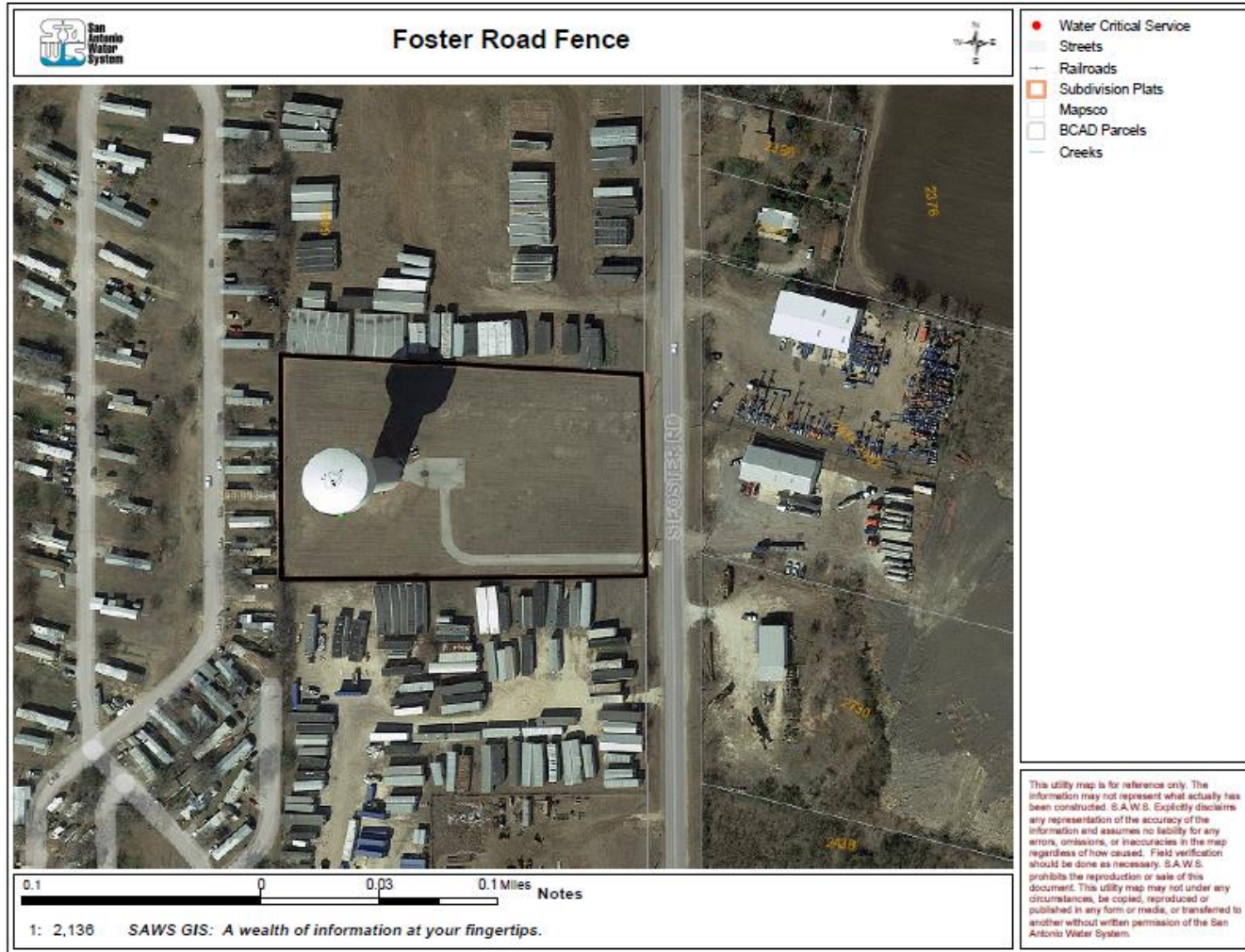



# Heavy Duty Cantilever Slide Gate

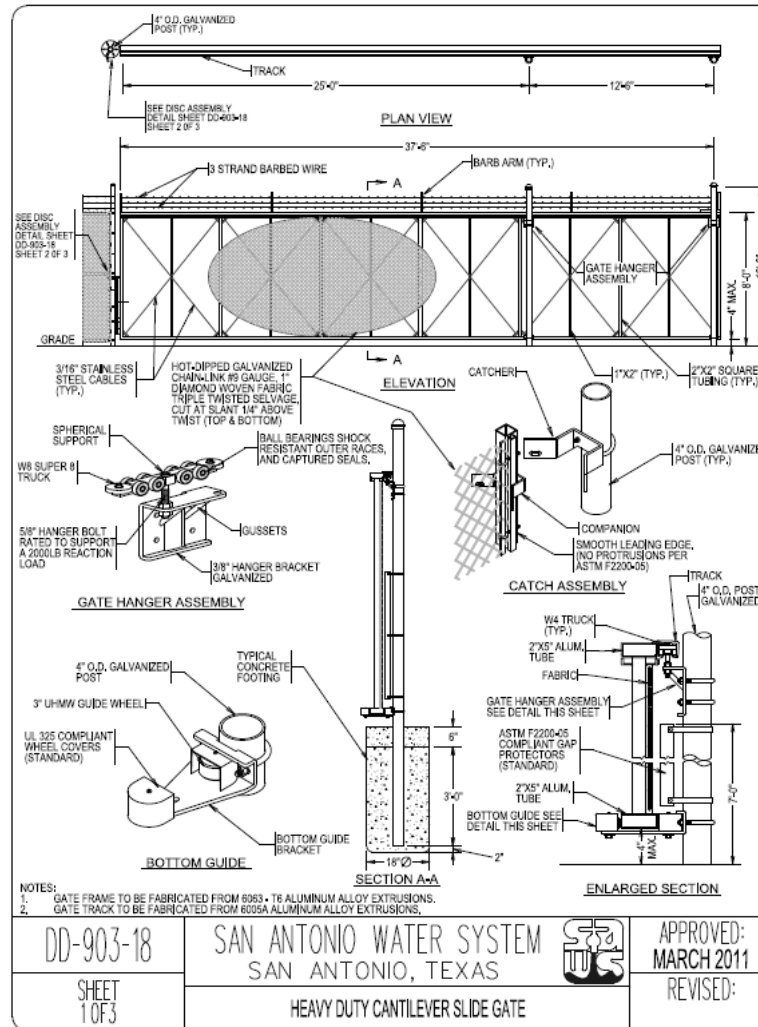

# Heavy Duty Cantilever Slide Gate

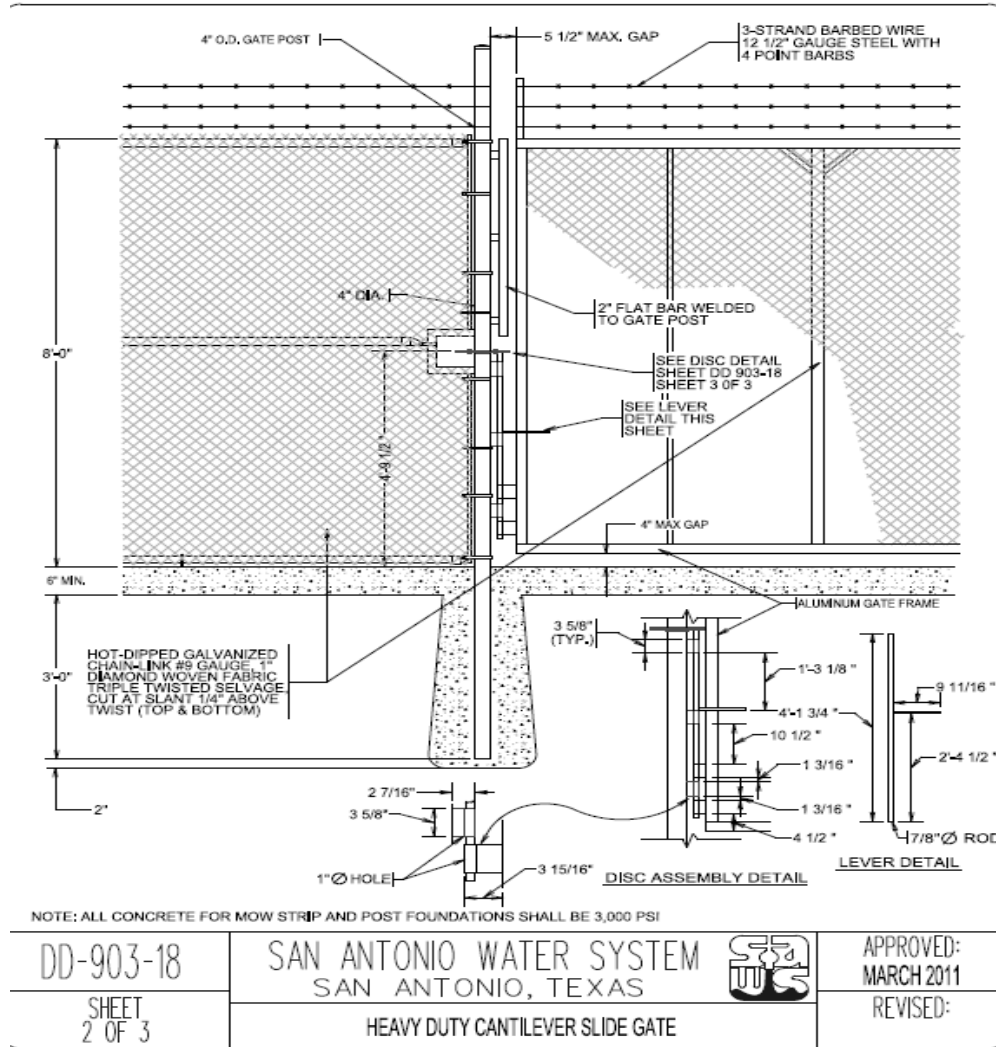



# Heavy Duty Cantilever Slide Gate – Disc Detail

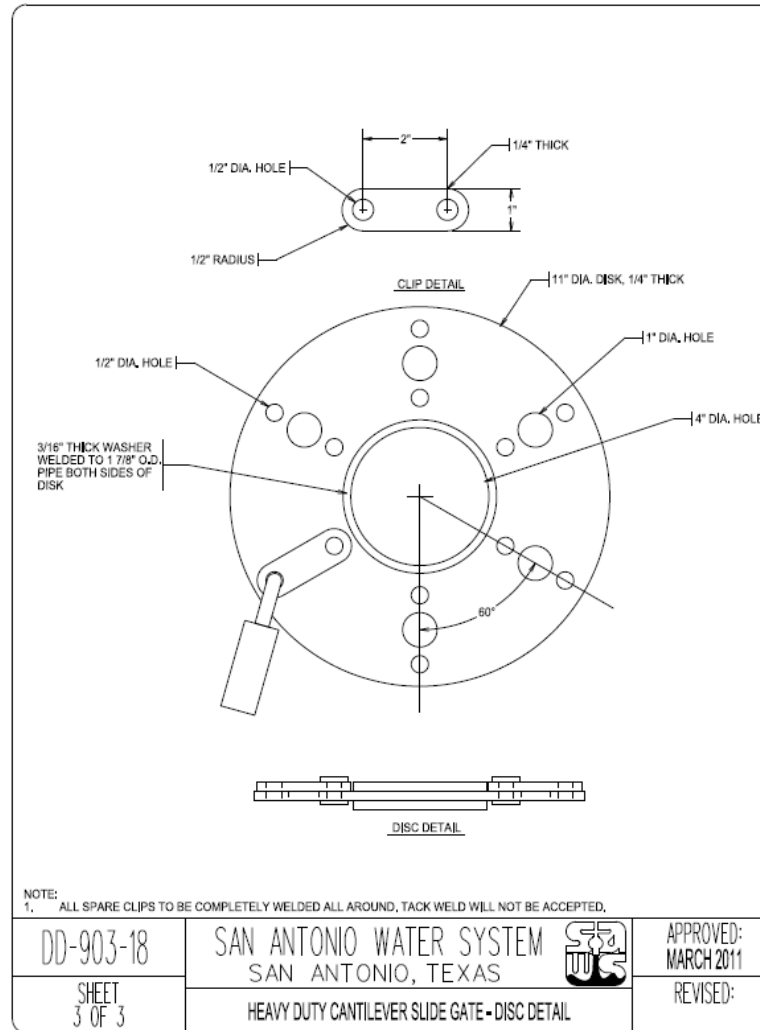

# Fence Details

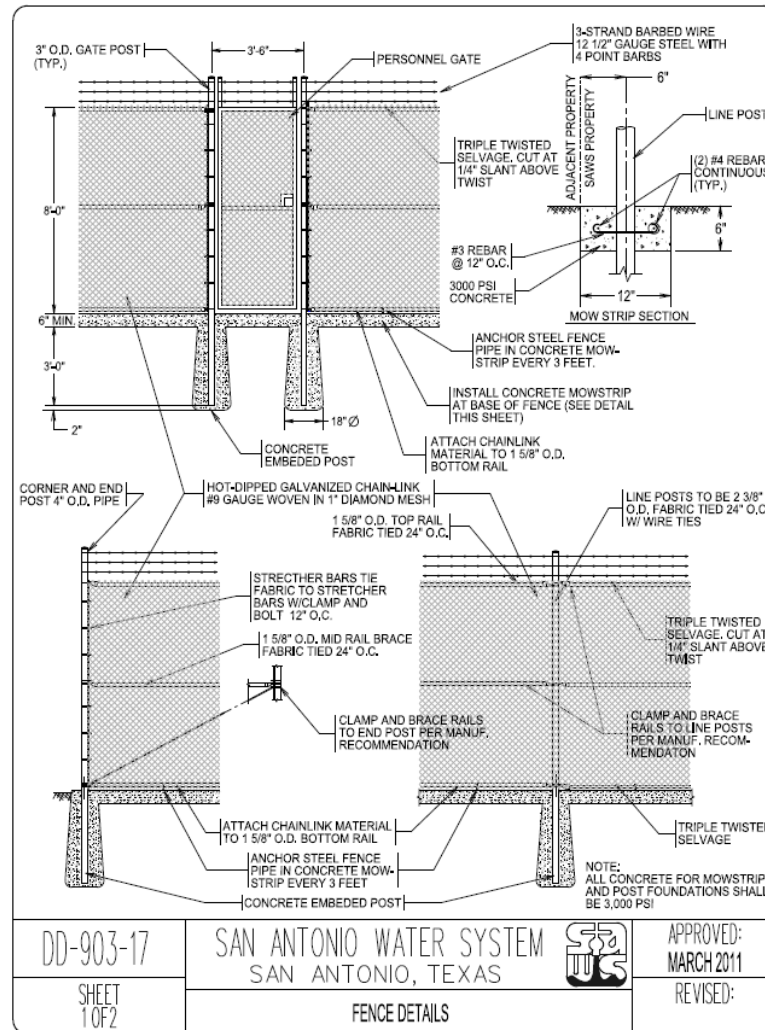

# Fence Details

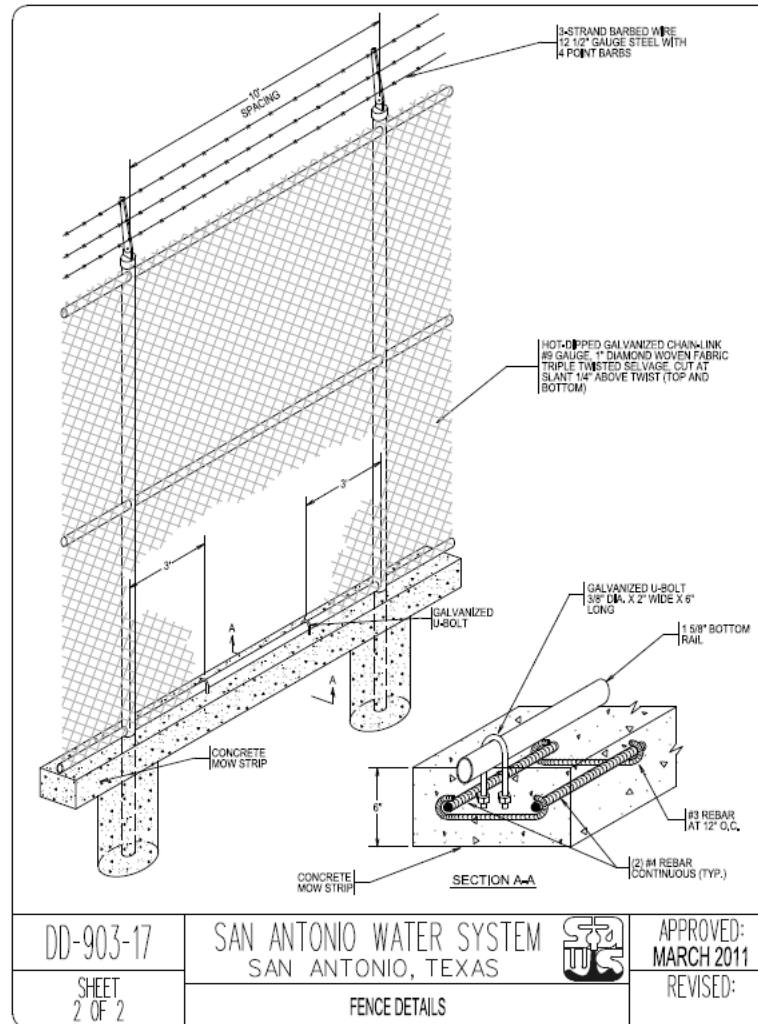



# Concrete Mow Strip

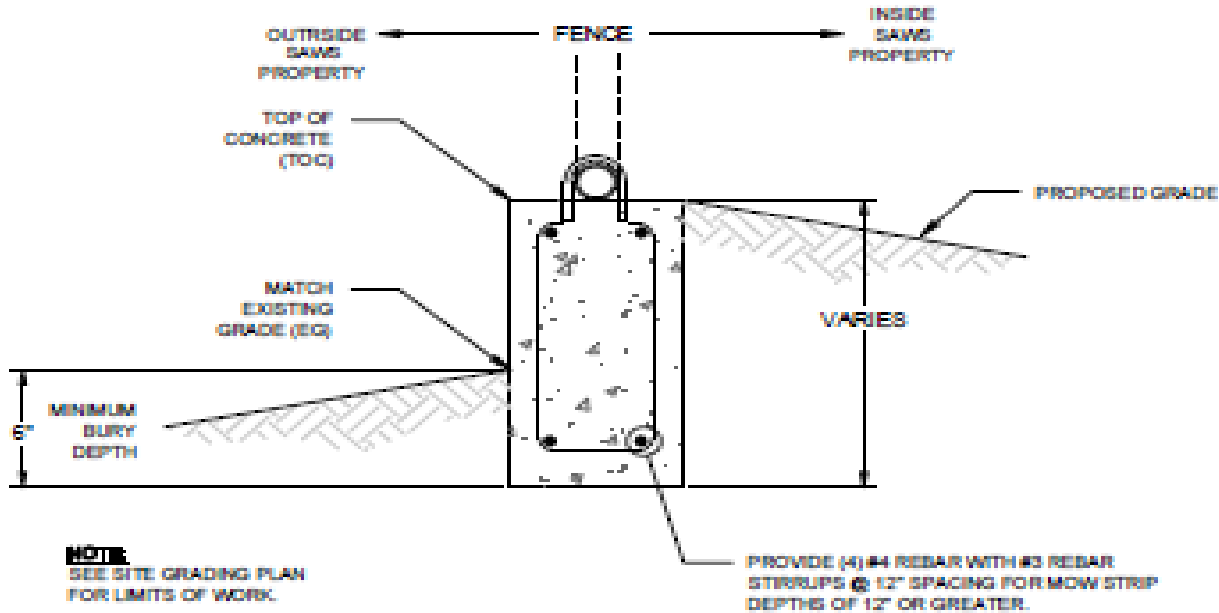

**CONCRETE MOW STRIP**

N.T.S.



# Example of Temporary Fence



			CHAIN LINK WIRE	
DIM. "A"	DIM. "B"	TUBING MATERIAL	GAUGE	DIAMOND SIZE
6'	14'	1-3/8" x 16 Gauge	12.5	2-3/8"



# Questions

# Special Conditions

- Be familiar with the sites before bidding
- Special Conditions
  - Submittal Requirements
- Note number of days for completion

# Key Dates

- Submit all questions in **writing** by August 24, 2015 no later than 4:00 PM CST to:

**Gina Cappa**

Contract Administration Specialist  
San Antonio Water System  
2800 U.S. Hwy 281 North, Suite 171  
San Antonio, TX 78212

E-mail: [gina.cappa@saws.org](mailto:gina.cappa@saws.org)

Phone: 210-233-3404

- Addendum Posted to SAWS website August 27, 2015 by 4:00 PM
- Bids due by August 31, 2015 no later than 10:00 AM
- Follow the specific delivery instructions



# Submittal Information

- To be submitted:
  - Bid Proposal and Acknowledgement of All Addendums
  - Proposal Certification; page PC-1
  - Bid Bond/Cashier's Check
  - Statement on President's Executive Orders – Page IB 6 or 7
  - Good Faith Effort Plan
  - Conflict of Interest Questionnaire - Form CIQ
  - Proof of Insurability (Letter from Insurer or Sample Certificate of Insurance)
  - W-9

# SMWB Evaluation Information

- Good Faith Effort Plan
  - Provide All sub-contractors on team;
  - Provide the work to be performed by sub-contractor;
  - Must identify the % participation related to the overall program;
  - Complete **Section C** only if goal is not met; and
  - All respondents must sign the Affirmation statement.

# SMWB Questions

- Potential SMWB sub-contractor listings available
- Forward SMWB questions until the proposal deadline directly to:

Marisol V. Robles

SMWB Program Manager

210-233-3420

[marisol.robles@saws.org](mailto:marisol.robles@saws.org)

# Reminders

- Use the Bid Proposal in the Specifications
- 45 Calendar Days to Complete Project
- Proposals Due: August 31, 2015 no later than 10:00 AM CST
- Delivery: 2800 U.S. Hwy 281 North, Suite 171 (Tower 2)



# Questions

# SAWS Production Facility Fence Replacement Project

**Carl Daylong**

Foreman – Facility Maintenance

**Gina Cappa**

Contract Administration Specialist – Contracting

August 20, 2015

SAWS Production Facility Fence Replacement Project

